



SMC Series Surface Mount LED Canopy

Lightstat's LED canopy provides a bright and clean appearance that saves more energy than metal-halide fixtures. It is designed for petroleum and general lighting applications.



KEY FEATURES

ILLUMINATION:

- Philips 3535 LEDs provide 13,200 lumens
- 5000K color temperature

ELECTRICAL:

- Universal 100VAC–277VAC
- 50,000 Hour rated lamp life
- 93% Driver efficiency
- Power factor: ≥ 0.95
- CRI: >80

MOUNTING:

- Pendant mount

HOUSING:

- Die-cast aluminum housing with durable white powder coat finish

WARRANTY/LISTING:

- DLC approved
- Tested to UL1598, UL8750 and IEC60598 safety norms
- *5 year warranty on all electronics and housing
- cULus listed for wet locations (-4F°–104°F)

DIMENSIONS:

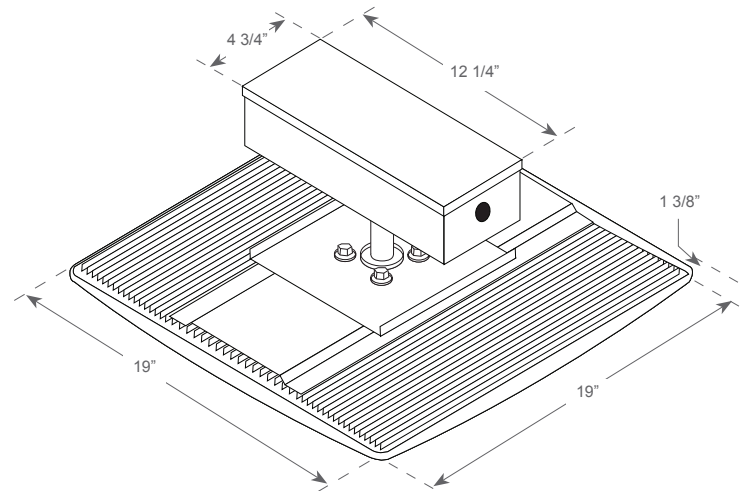

ORDERING INFORMATION

Example: MODEL-WATTAGE-COLOR TEMP
i.e., "SMC-120W-5K"

MODEL	WATTAGE	COLOR TEMP
SMC	120W	5K

Specification is subject to change.

*Warranty does not apply to installation errors, natural disasters, and/or abuse.

