



SAL Series

Small Multi-Purpose 15W LED Area Light

Lightstat's cost-effective, multi-purpose, architectural LED area lights are ideal for illuminating parking lots, loading docks, doorways and pathways.



KEY FEATURES

ILLUMINATION:

- Lumileds LED provide 1450 lumens
- Available in 5000K color temperature

ELECTRICAL:

- Universal 100VAC-277VAC
- 50,000 Hour rated lamp life
- 88% Driver efficiency
- Tovin LED Driver Manufacturer
- CRI: >80

MOUNTING:

- Available with adjustable yolk mount or adjustable, heavy duty die-cast knuckle mount with 1/2" NPS stem with locking nut

HOUSING:

- Die-cast aluminum housing with durable dark bronze powder coat finish
- Polycarbonate light cover

WARRANTY/LISTING:

- cULus listed for wet locations (-22° F-104°F)
- DLC approved
- IP65 Rated
- Tested to UL1598, UL8750 and IEC60598 safety norms
- *5 year warranty on all electronics and housing

DIMENSIONS:

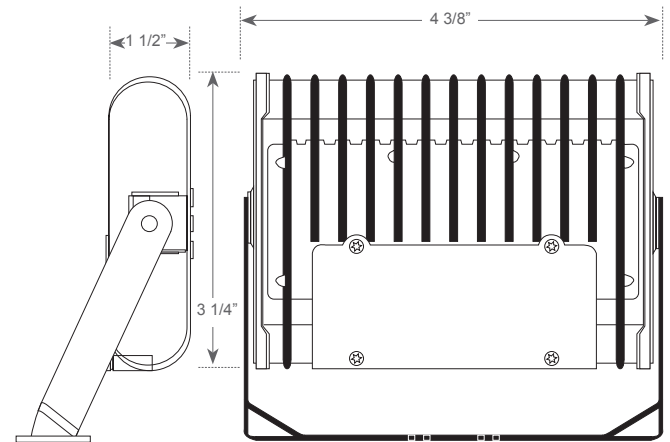

MOUNTING OPTIONS:



Yolk Mount
YM



Knuckle Mount
KM

ORDERING INFORMATION

Example: MODEL-WATTAGE-COLOR TEMP-MOUNTING OPTIONS
i.e., "SAL-15W-5K-YM"

| MODEL | WATTAGE | COLOR TEMP | MOUNTING OPTIONS | |
|-------|---------|------------|------------------|---------------|
| SAL | 15W | 5K* | YM | Yolk Mount |
| | | | KM | Knuckle Mount |

*Consult factory for additional color temperatures.
Specification is subject to change.

*Warranty does not apply to installation errors, natural disasters, and/or abuse.

