



# Surface Edgelit Exit Sign



## KEY FEATURES

### ILLUMINATION:

- Ultra bright, energy efficient, Red or Green LEDs
- UV-stabilized ultra-clear acrylic edgelit panel provides consistent, uniform illumination
- Double face utilizes factory installed silver or white mylar background panel

### ELECTRICAL:

- Dual 120/277VAC standard. Optional special voltage of 208/220/240VAC available
- Charge rate power "ON" LED indicator light and push-to-test switch for mandated code compliance testing
- 4.8V long life, maintenance-free, rechargeable NiCd battery
- Internal solid-state transfer switch automatically connects the internal battery to LED board for minimum 90-minute emergency illumination
- Fully automatic solid-state, two rate charger initiates battery charging to recharge a discharged battery in 24 hours

### MOUNTING:

- Aluminum mounting canopy included for top, end or back mount

### HOUSING:

- Premium-grade, extruded aluminum housing (also available in black or white powder-coated finishes)
- Self-adhesive chevrons and guide template provided for directional indication

### WARRANTY / LISTING:

- \*5 year warranty on all electronics and housing. Battery pro rated for 5 years
- Meets UL924, NFPA 101 Life Safety Code, NEC, OSHA, Local and State Codes
- UL Listed for damp locations (32°F–122°F)

### OPTIONS:

- **SD:** Self-diagnostic feature performs monthly, biannual, and annual tests to ensure reliable operation and meet electrical and life safety codes
- **2C:** Dual circuit option on the AC-only unit enables it to be connected to two different (one acting as a back-up to the other) supplies at the same time
- **CW:** Custom verbiage signs available on request
- **SPV:** UL Listed for special voltage option = 208/220/240VAC
- **USA:** Substantial transformation assembly in the U.S. complies with "Assembled in the USA" under the Buy American Act

### DIMENSIONS:

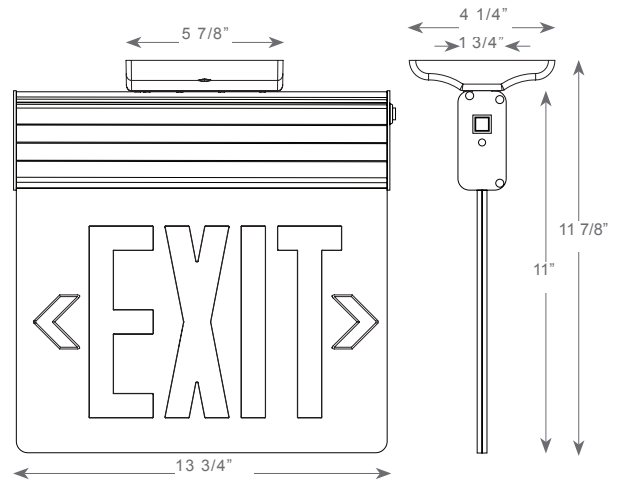

## ORDERING INFORMATION

Example: "EL-1RC-A-A-2C-USA"

MODEL	No. of FACES	LETTER COLOR	PANEL	BATTERY	HOUSING COLOR	OPTIONS
EL	1	Single Face	R Red	C Clear	A AC Only	SD <sup>1</sup> Self-diagnostics
	2	Double Face	G Green	M Mirror	N NiCad Battery	2C <sup>2</sup> Dual Circuit Operation
			W White	W White	A Aluminum	CW Custom Wording
						USA Assembled in USA
						SPV 208/220/240VAC, 50/60Hz

### NOTES:

1. Available on NiCad exits only.
2. Available on AC only exits.

Specification is subject to change.

\*Warranty does not apply to installation errors, natural disasters, and/or abuse.

