



Wet/Cold Location Combo Unit



KEY FEATURES

ILLUMINATION:

- Long lasting, efficient, ultra bright white LED lamp heads
- 3.6W (3 LEDs x 1.2 watts) per head
- Adjustable LED lamp heads provide optimal center-to-center spacing
- Long-life, energy efficient Red or Green LEDs EXIT sign illumination

ELECTRICAL:

- Dual 120/277VAC
- Unique bi-color LED indicator light alerts occupant on battery condition (Green-normal, Red-check battery)
- 6V long life, maintenance free, rechargeable NiCd battery
- Internal solid-state transfer switch automatically connects the internal battery to LED board and lampheads for minimum 90-minute emergency illumination
- Fully automatic solid state, two rate charger initiates battery charging to recharge a discharged battery in 24 hours

MOUNTING:

- Die-cast aluminum mounting canopy included for top or end mount
- Universal K/O pattern on back plate for wall mount

HOUSING:

- 5VA flame retardant, UV stabilized polycarbonate in white, black or gray finish
- High-impact resistant, UV stabilized polycarbonate clear lens
- Corrosion resistant enclosure with engineering grade silicone gasket
- Top and side K/O's provided for conduit feed applications
- Snap-out Chevron directional indicators

OPTIONS:

- **SD:** Self-diagnostic feature performs monthly, biannual, and annual tests to ensure reliable operation and meet electrical and life safety codes
- **TRH:** Tamper-resistant hardware helps prevent unauthorized access to the unit
- **CL:** Optional internal heater and battery blanket for extreme cold temperature applications (-4°F–122°F)

WARRANTY / LISTING:

- *5 year warranty on all electronics and housing. Battery pro-rated for 5 years
- Meets UL924, NFPA 101 Life Safety Code, NEC, OSHA, Local and State Codes
- UL listed for wet locations (32°F–122°F)

DIMENSIONS:

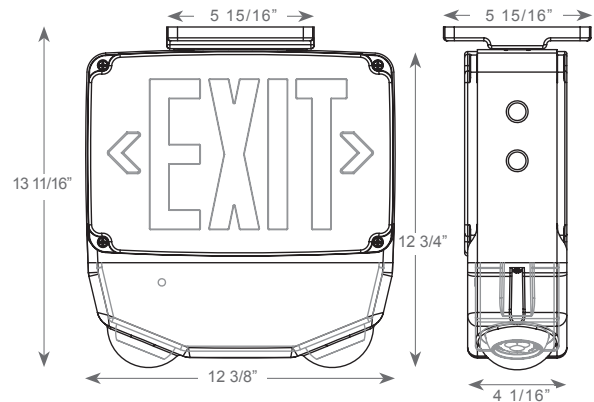

ORDERING INFORMATION

Example: "CW-1R-W-RC-SD"

MODEL	No. of FACES	LETTER COLOR	HOUSING COLOR	OPTIONS	
CW	1	Single Face	R Red	W White	TRH Tamper Resistant Hard
	2	Double Face	G Green	B Black	CL Cold Location
			G Gray (with white faceplate)	RC Remote Capacity	SD Self Diagnostics

Specification is subject to change.

*Warranty does not apply to installation errors, natural disasters, and/or abuse.

